

Simplex Anaesthetic Gas Scavenging System

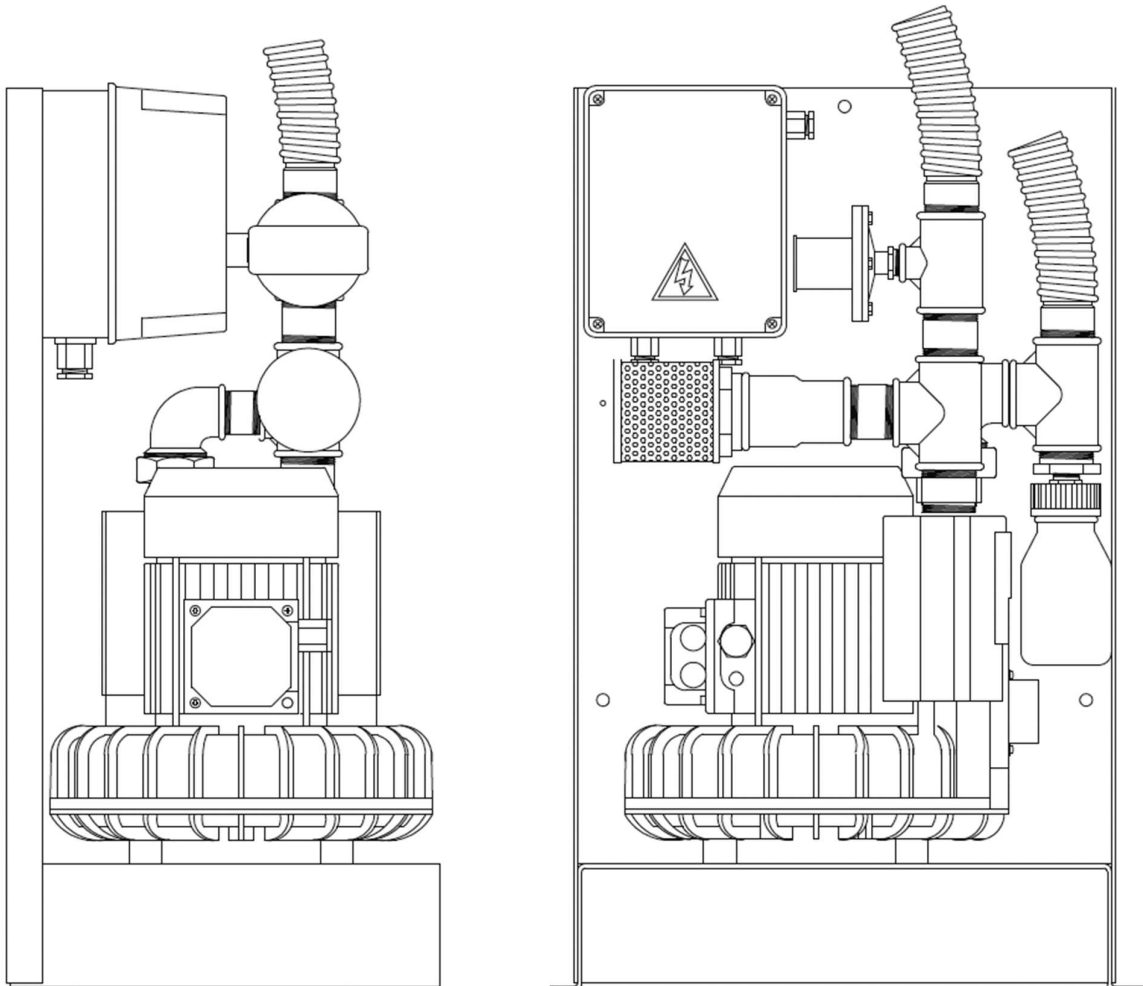

Table of Contents

About this manual 4

Environment 4

Structural 4

Mounting..... 5

Electrical connections 5

Mechanical 7

Setting Up..... 7

Operator 8

Operation15

Maintenance16

Symbols.....17

UDI-DI & UDI-DI Label18

Spares Parts list.19

Control Panel Variations20

Pump/ Overload & Motor Rated Fuse Variations21

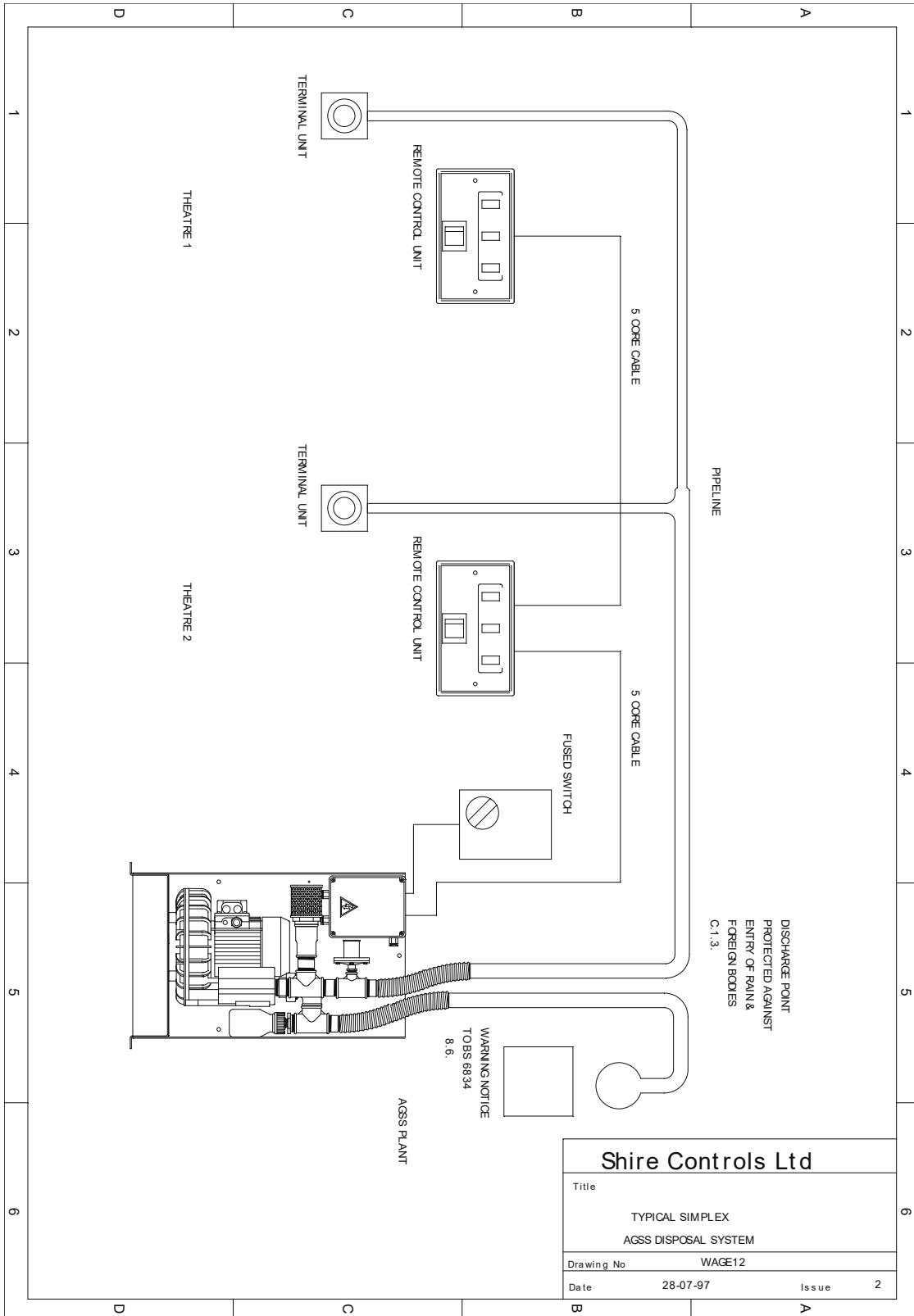

About this manual



When you see this symbol, the associated text in bold type refers to something which may cause danger or damage.

Environment

UKCA & EU MDR 2017/745 Compliant

This device is intended for use in a dry, indoor environment such as a hospital plant room, where abnormal levels of airborne dust or condensation are not expected. It is designed to operate safely and effectively under the following environmental conditions:

- **Operating Temperature:** +5°C to +40°C
- **Storage Temperature:** -10°C to +50°C
- **Operating Humidity:** 10% to 85% RH (non-condensing)
- **Storage Humidity:** 10% to 85% RH (non-condensing)
- **Maximum Altitude:** 1000 metres above sea level

These limits are established to ensure continued performance and safety, avoiding degradation due to condensation or environmental extremes. The design excludes batteries and is suitable for technical areas with standard climate control, aligning with EU MDR General Safety and Performance Requirements (Annex I, Chapters II & III).

Structural

The Simplex AGSS unit must be installed on a firm, level, non-combustible surface capable of supporting the weight of the unit, associated components, and any service access requirements.

Mounting Requirements:

- The plant must be securely fixed using the four designated mounting holes in the chassis frame.
- The mounting surface must prevent vibration transmission and accommodate potential thermal expansion.
- Mechanical anchoring must ensure the plant cannot shift during operation or seismic activity (where applicable).
- Minimum clearance must be provided around the unit for ventilation, maintenance, and inspection:
 - At least 300 mm clearance on all sides.
 - Minimum enclosure volume: 3 cubic metres per kilowatt of motor power to ensure adequate air exchange.

Protection from External Forces:

- Where located in areas subject to trolley or vehicle traffic (e.g., plant rooms with maintenance access), appropriate barriers or guards should be installed to prevent impact damage.

Corrosion and Moisture Considerations:

- The unit is intended for indoor use in dry environments. The installation site must prevent exposure to condensation, spray, or prolonged humidity above design specifications (10–85% RH, non-condensing).
- Do not install the unit where it may be exposed to corrosive vapours or standing water.

Structural Interfaces:

- Pipework connected to the suction and discharge ports must be mechanically supported and stress-free. Flexible couplings should be used to prevent strain on the unit fittings.
- The supporting structure and fixing method must comply with local building regulations and any relevant hospital infrastructure standards.

Platform Load Capacity:

- The platform or supporting structure must be rated for a minimum static load of 150 kg. This allows for the heaviest unit configurations, a technician's service access, and a 25% safety margin.

Mounting



Consideration should be given to the likelihood of the plant being struck by passing traffic & additional protection provided if necessary. The plant must be fixed by means of the four mounting holes in the frame of the plant. Ensure a free flow of air to the motor. If the pump is mounted in an enclosure, allow a minimum of 3 cubic metres per kilowatt of motor power of air space within the enclosure.

Electrical connections



The plant must be supplied from a fused switch isolator with provision for locking in the OFF position, mounted between 0.6 and 1.9 metres above the servicing level in an easily accessible position.

The prospective fault current must not exceed 1.5kA. The earth fault loop impedance of the supply must not exceed 1 ohm.

Type	Power (kW)	Amp (1ph)	Amp (3ph)	Noise dB(A) @ 1 metre
AGS120	0.4	3.1	NA	58
AGS120	0.4	NA	1.4	58
AGS130	0.75	5.5	NA	64
AGS130	1.1	6.0	NA	64
AGS130	0.75	NA	2.7	64
AGS130	1.1	NA	3.0	64
AGS141	1.1	7.6	N/A	71
AGS141	1.5	9.0	N/A	71
AGS142	1.5	N/A	4.0	68

Three phase plant.

Note. This plant requires a neutral. See Drawing WAGE8

Single phase plant.

See Drawing WAGE10

All plant.



Replace fuses only with motor rated fuses, rated at the motor full load current. Do not use this plant with any control, indication or interface system other than that supplied by the manufacturers.

A relay interface is available giving volt-free contacts rated at 5 amps, 240 volts resistive, for Power on, System On and System Failed signals, and providing input terminals for control from volt-free contacts.

When using remote control units or relay interfaces, connect the terminals on the lower edge of the printed circuit board in the control panel marked RUN, SF, -Ve, +Ve & CTL to the corresponding terminals on the remote-control units or relay interfaces.

A maximum of 6 remote control units may be used with a control panel. The voltage drop on the cable to the remote-control units should not exceed 1.2 volts. (the current drawn is .017 amps per remote control unit + .03 amps. 6 remote control units could be used on 300 M of 1.5mm cable) Cable exceeding 2.5mm should not be used.



When using a relay interface, connect the terminals marked "Local" on the relay interface to the contacts which will control the plant e.g. theatre panel switch. **These contacts must be volt-free.**



Use the contacts on the relay interface to switch other circuits as required. When using the relay interface to switch indicator lamps on theatre panels etc. we strongly recommend that System On and System Failed conditions are displayed as a minimum, and that lamps are used which are of equal brightness and reliability to the lamps used on the standard remote control unit, When not using remote control units or relay interfaces, link the terminals marked +Ve & CTL.

Mechanical

Connect the suction & discharge hoses to the plant and pipelines as shown on drawing WAGE12.

Setting Up

Check the rotation of the motor on three phase plant (see arrow on Pump chassis). If the rotation is incorrect, isolate the supply and reverse two phases.

With all remote-control units switched off, check that the pump is not running and that all remote-control units show a Power On lamp only.

Switch on each remote-control unit in turn. As the pump switches on, the System Failed lamp will come on momentarily as the pump produces vacuum in the pipeline, followed by the System On lamp. Switch off this remote-control unit & continue to the next.

If the System failure lamp does not operate correctly, reset the pressure switch as follows:

- Disconnect the suction hoses from the plant.
- Switch on the plant.
 - If the System Failure lamp is on, turn the pressure switch adjusting nut (see drawing WAGE4) anticlockwise until the System Failure lamp goes out. Turn the adjusting nut clockwise until the System Failure lamp comes on and continue for 3/4 turn (If the system is operated at an exceptionally low vacuum, it may be necessary to use a lower setting).
- Replace the suction hose and pressure switch cover.

Set up the system flow as described in current standards, using the balance valve to set the operation vacuum in the pipeline.

Operator

Typically, the operator should be at one of the 6no Remote Control Switches. Technical servicing would be at the Control Panel at the main plant.

Each Remote-Control Switch Unit includes:

- Three long-life, block LEDs which show the conditions of the service through a wipe-clean membrane. The inherent design includes Red/Green LED variations as per industry HTM guidelines and the use of colour recognition ensures that the unit can be monitored comfortably from a distance of 3-4 metres.
- A On/Off rocker switch. This comprises two poles.
 - One pole to 'call' the pump and switches on the vacuum, by bring the CTRL to +Ve.
 - One pole to enable the Duty Run, Standby In Use or System Fault LEDs.
 - (the Power ON LED will be ON whenever the Plant Isolator is ON)

The Central Plant Control Panel Includes:

- Thermal Trip. Where the pump chassis has reached 85deg C (or higher) the Thermal Trip will fail open circuit to switch the Pump Off, this will cause the System Fault LED to show on each remote-control unit.



The Thermal trip switch is in series with the 230vac switched feed to the contactor coil (which is used to switch on/off the 1 or 3 phase Pump supply). The thermal trip cover carries a Main Warning label indicating the 230vac present through the Thermal Trip. Follow these steps:

- Isolate the power to the Plant.
- Remove the cover.
- Press the reset button within.
- Replace The cover.
- Resume the power to the plant.

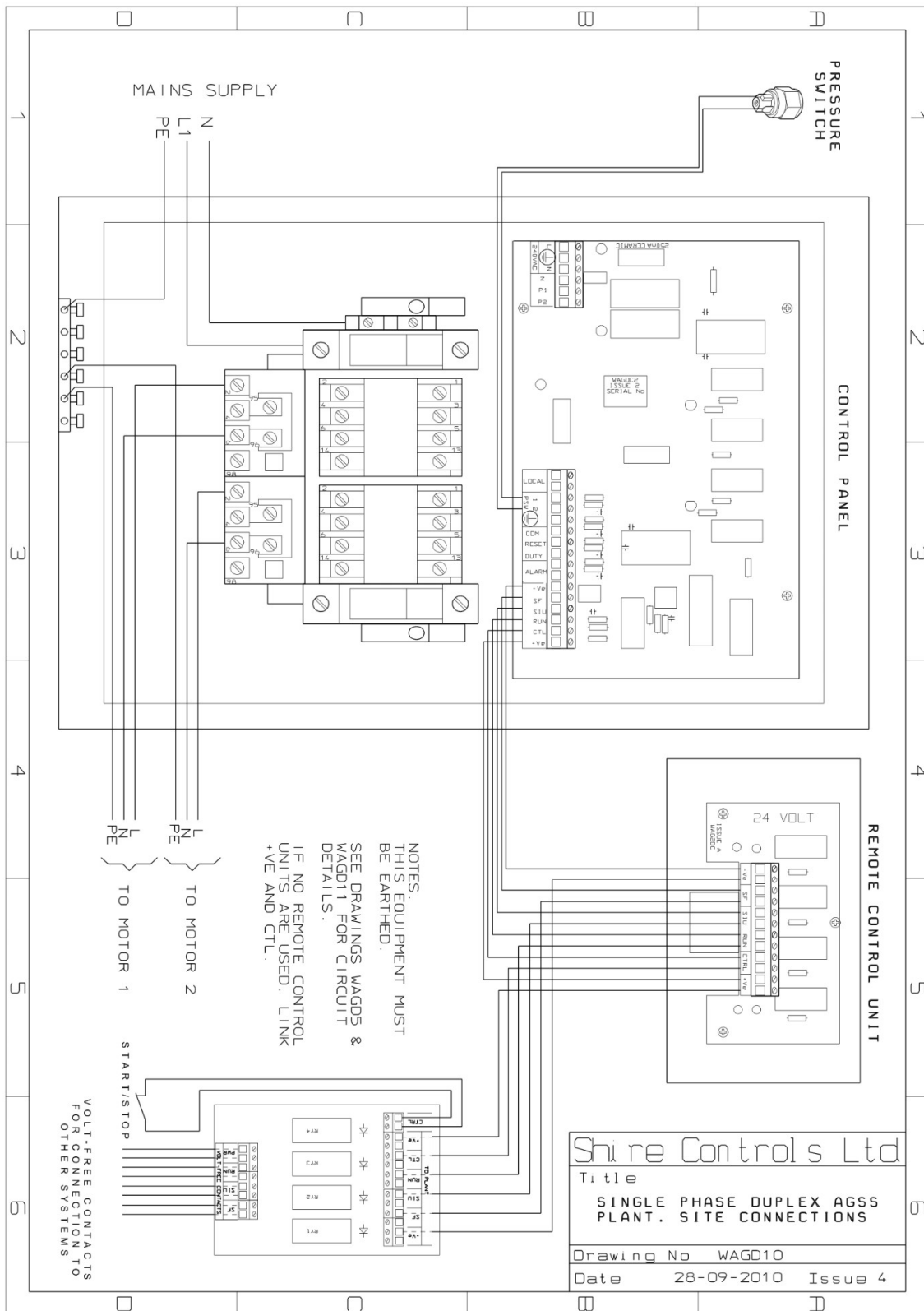

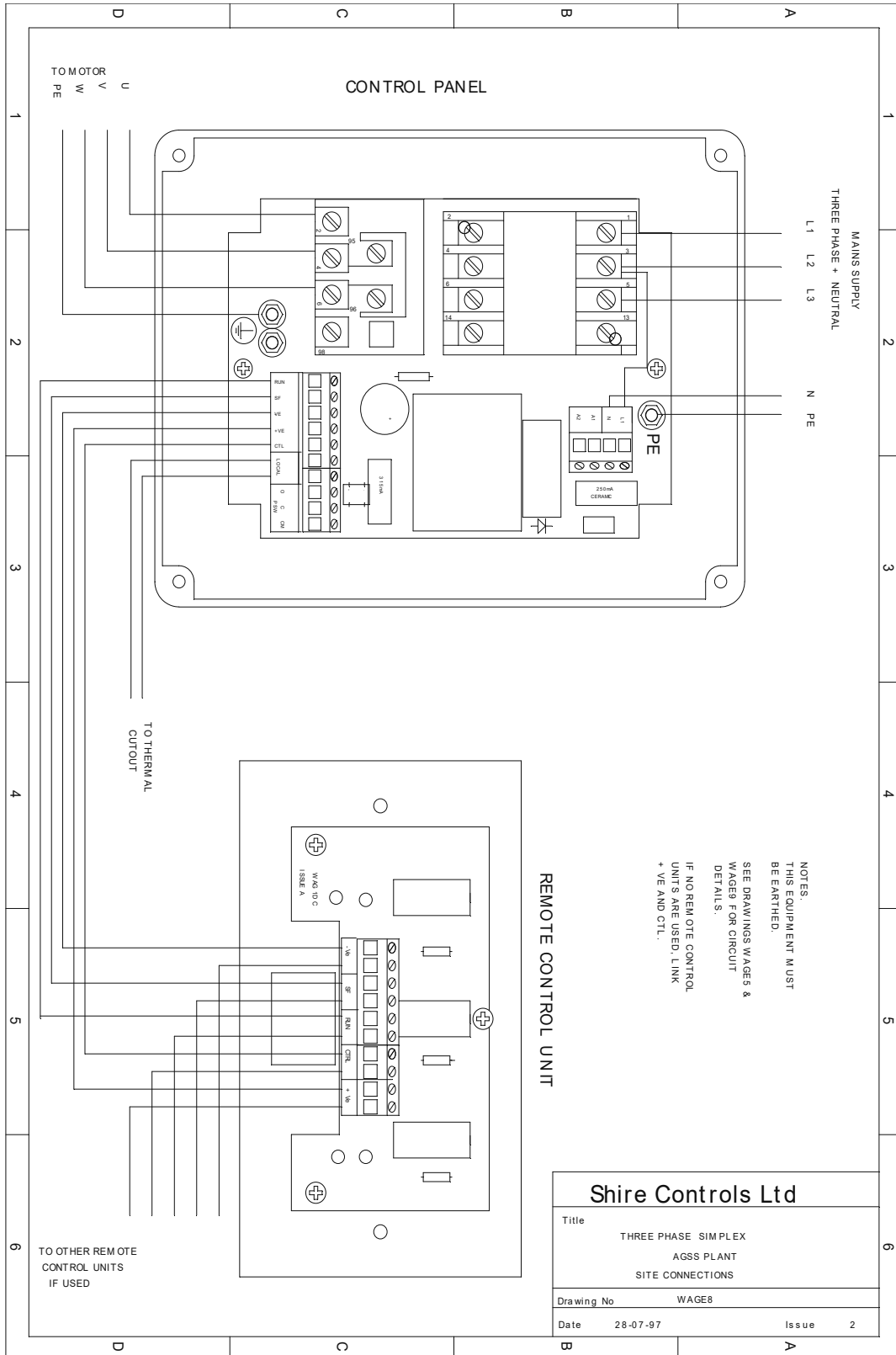

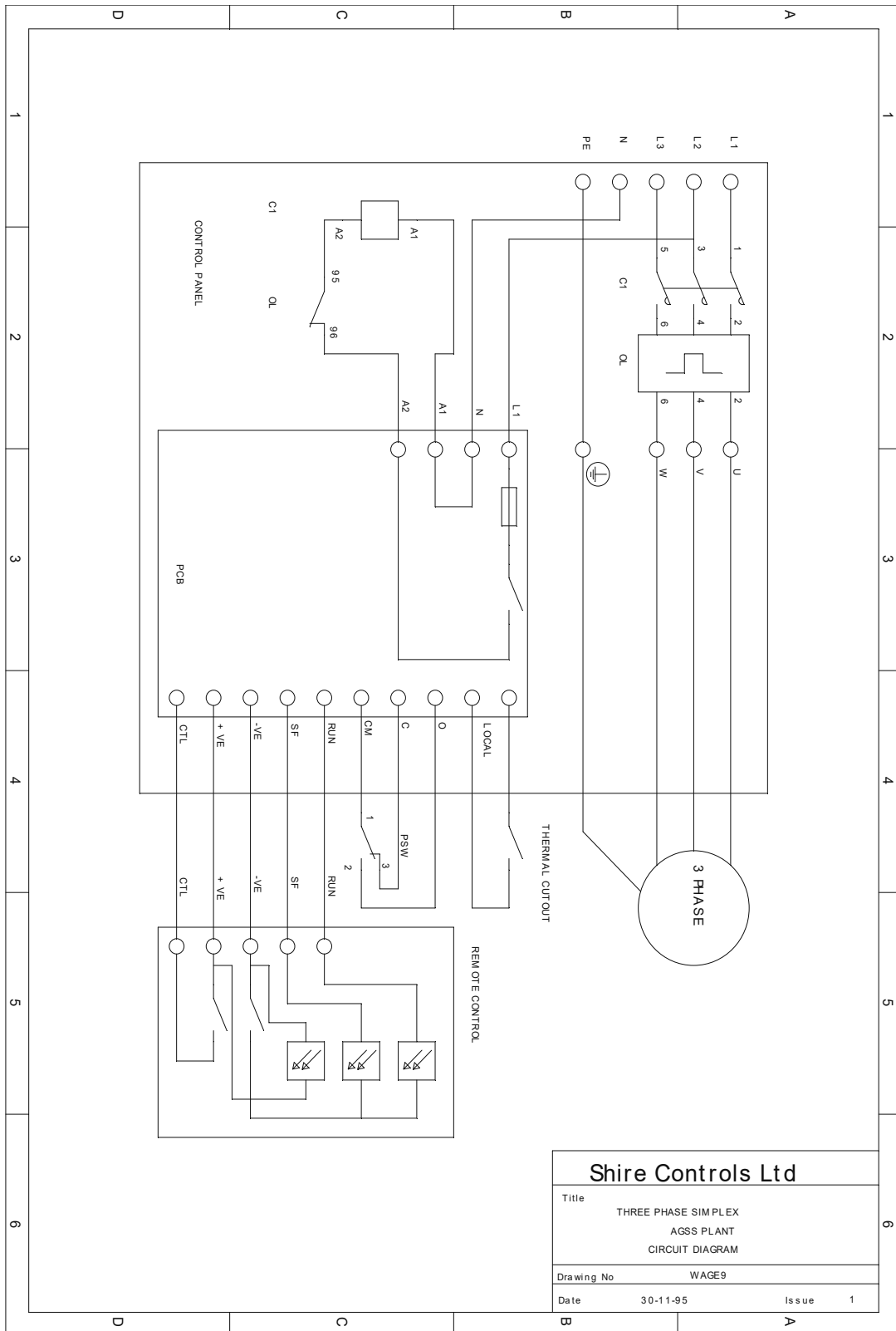

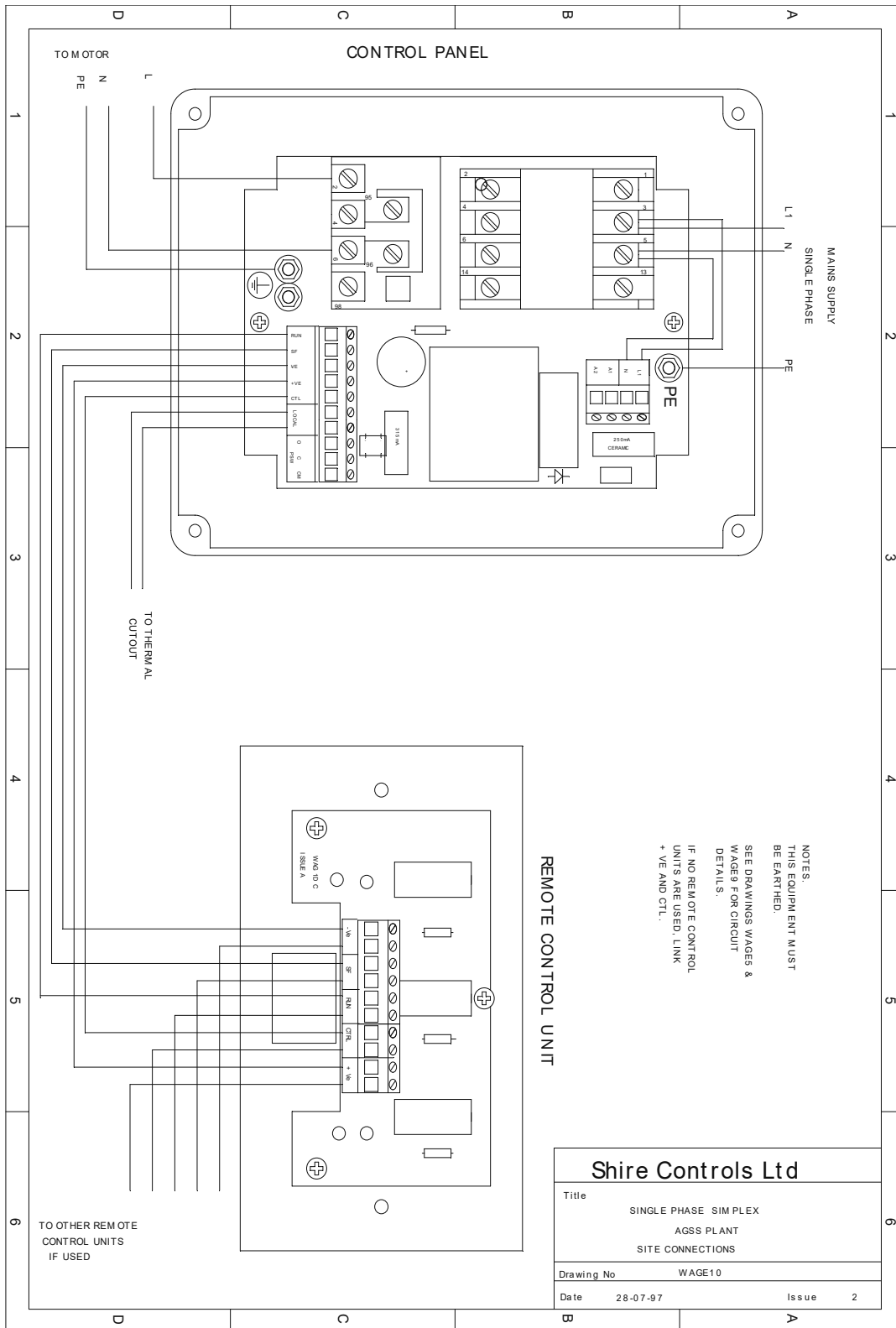

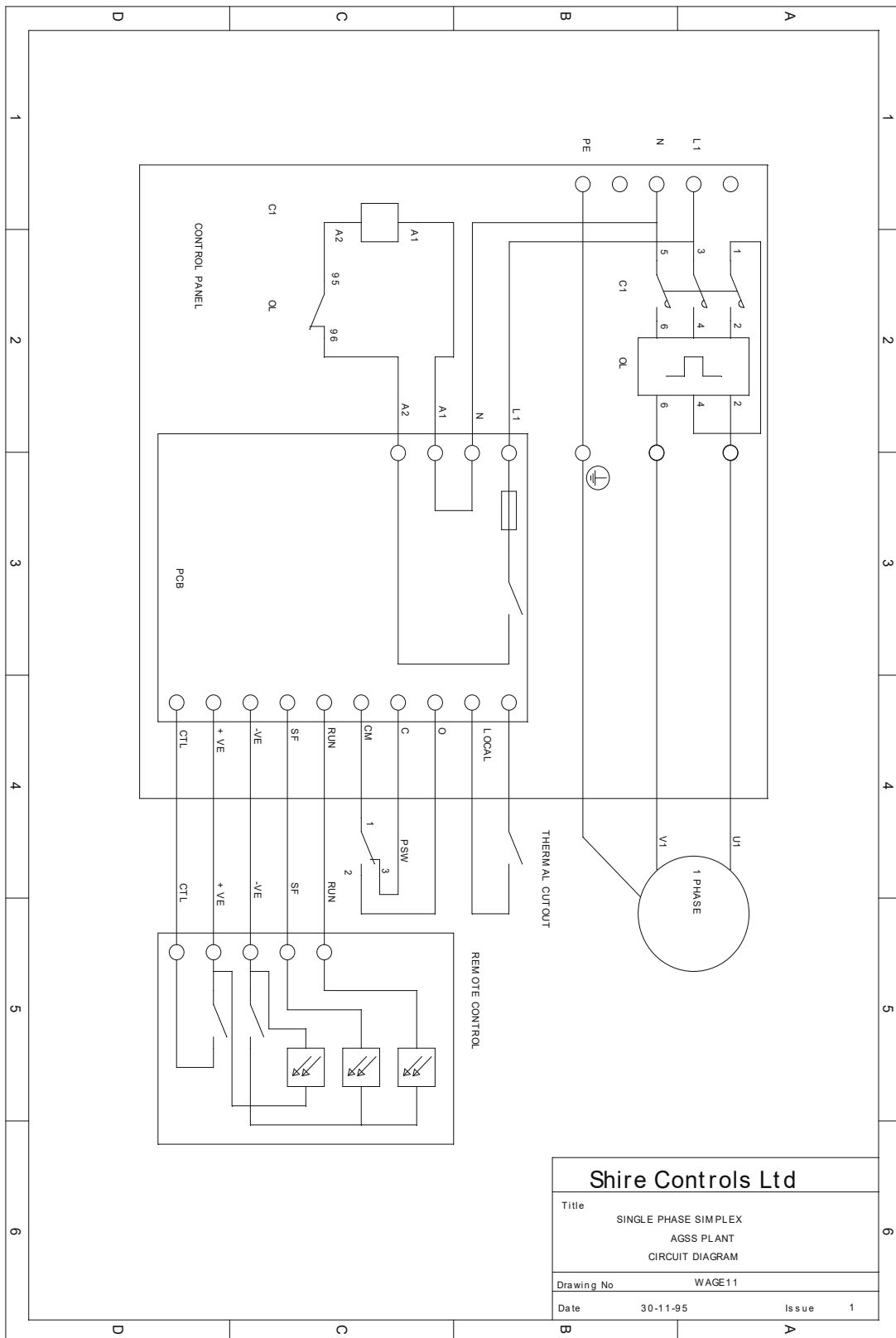



IMPORTANT. Ensure that an air flow is maintained through the pump via the balance valve when all terminal outlets are closed. Failure to allow an air flow will result in overheating of the pump with possible damage to the pump, motor and hoses and possible injury to personnel.

The following minimum flow rates should be observed.

AGS120 = 130 l/m

AGS130 = 650 l/m

AGS141 = 1170 l/m

Operation

Switching on any remote-control unit will start the plant. Indication of System On or System Failure will only be given at any remote-control unit which is switched on. Any units switched off will show Power On only.

The plant will continue to run until all remote-control units are switched off. On initial start-up, the System Failure lamp will show momentarily as the pump produces a vacuum in the pipeline. This will change to System On as vacuum is produced. If the pump fails to produce vacuum, the System Failed lamp will show.

The pump is protected against overheating by a thermal cut-out mounted on the end of the pump (see drawing WAGE4). If the thermal cut-out operates, reset the cut-out by isolating the plant, removing the cover (with main warning label affixed) & pressing the reset button. Establish the cause of the overheating before putting the plant back into service. Two causes of overheating are a lack of air flow through the pump when no outlets are in use, or inadequate ventilation for the pump and motor cooling.

An alarm output in the form of volt-free contact is closed under normal operating conditions, rated at 50 V dc, 50mA. This contact will open if the power fails, or the pump fails to draw the designated vacuum set on the pressure switch.

Maintenance

The filter on the balance valve must be cleaned or replaced periodically. The frequency of these inspections will depend on operating environment & should be determined by experience.















Every 6 months.

- Switch Off the mains supply from the nearby Isolator (by others).
- Remove mains fused protection between Isolator and Control Panel (also by others).
- Switch the Isolator back on.
- Disconnect the suction hose.
- Go to each remote-control unit (at which the plant conditions are displayed) in turn.
- Check that the System Failed lamp comes on.
- Replace the suction hose.







Every 2 Years

- Switch Off the mains supply from the nearby Isolator (by others).
- Remove mains fused protection between Isolator and Control Panel (also by others).
- Dis-assemble and clean the Balance Valve.
- Clean or replace the Balance Valve filter.
- Replace Thermal Trip & Lead.

Symbols

Symbol	Explanation
	Medical Device
	Do not use if package is damaged and consult the instructions for use
	Humidity Limitation
	Keep Away from Sunlight
	Non-Sterile
	Keep Dry
	Caution
	Fragile
	Storage Temperature
	Manufacturer
	Date of Manufacture
	Serial Number
	Observe the Instructions for use
	UKCA Marking
	CE Marking European Union directives & regulations (including (EU) 2017/745 MDR)

UDI-DI & UDI-DI Label

 <p>Simplex AGSS Anaesthetic Gas Scavenging System</p>	<p>AGS130 simplex plant</p> <p># Model No. agss1203s</p>	   
<p>QTY: 1</p> <p>SN 1234</p> <p>UDI</p> 	<p>(01) 5061122261234</p> <p>(11) 2026-04-15</p> <p>(21) 1234</p>	<p>NON STERILE</p> <p>Shire Controls Ltd Studio 3 Channoicks Farm, Gilston, Harlow, Essex CM20 2RL, UK shiremedical.co.uk</p> <p>UK CA</p> <p>EC REP</p> <p>OMC NI Medical Unit 763, Moat House Business Centre, Belfast BT5 5AD, UK (Northern Ireland only)</p> <p>CE 0297</p> <p>2026-04-15</p>

	<p>INSTRUCTIONS FOR USE Shire Controls Ltd. Simplex AGSS</p>
---	--

Spares Parts list.

Description	Part Number	Supplier
AGSS Simplex Frame	SH021	Shire Controls Ltd
Balance valve	SH215	Shire Controls Ltd
Balance Valve Filter	SH912	Shire Controls Ltd
Drain Flask, Ring & Cap	SH377 / SH378 / SH379	Shire Controls Ltd
Pressure Switch	SH490 or Type 157 -400 mBar	Shire Controls Ltd Bailey & Mackey
Cre-A-Flex Hose 1.5 inch	SH375	Shire Controls Ltd
Cre-A-Flex Hose 2 inches	SH381	Shire Controls Ltd
Control Panel	agsssimplexxx_xxpanelxph	Shire Controls Ltd
Control Panel Box	GW44217 or SH126	Gewiss or Shire Controls Ltd
Control PCB WAGB ISS4	agsssimplexpcbrest	Shire Controls Ltd
Contactor	3RT10 17-1AP01 or SH357	Siemens or Shire Controls Ltd
Overload (See Pump Tables)	3RU1116-1**0 & SH**	Siemens or Shire Controls Ltd
Alternatives: -		
Contactor	5.5Kw	IMO, Lovato
Overload	To Match Contactor	IMO, Lovato
PCB Fuse F1 250mA ceramic	S501 250mA	Bussman
PCB Fuse F2 & F3 2A	S500 2A	Bussman
Simplex Pressure Switch Lead Assembly	agsspswlead	Shire Controls Ltd
Simplex Thermal Trip Lead Assembly	agssstlead	Shire Controls Ltd
Remote control (Flush)	wag1240f	Shire Controls Ltd
Remote control (Surface)	wag1240s	Shire Controls Ltd
AGSS Relay Interface	wagris	Shire Controls Ltd

Control Panel Variations

Single Phase Pump Control Panel Part Number	Pump Specification
agsssimpler11_16panel1ph	1 Phase Pump With 1.1-1.6 Running Current
agsssimpler14_20panel1ph	1 Phase Pump With 1.4-2.0 Running Current
agsssimpler22_32panel1ph	1 Phase Pump With 2.2-3.2 Running Current
agsssimpler28_40panel1ph	UNI-JET 75 120 230vac 0.4Kw 3.1A
agsssimpler35_50panel1ph	1 Phase Pump With 3.5-5.0 Running Current
agsssimpler45_63panel1ph	1 Phase Pump With 4.5-6.3 Running Current
agsssimpler55_80panel1ph	TECNO JET 130 230vac 0.75Kw 6A
agsssimpler70_100panel1ph	FLUX JET 141 230vac 1.1Kw 7.6A
agsssimpler90_120panel1ph	FLUX JET 141 230vac 1.5Kw 10.0A
Three Phase Pump Control Panel Part Number	Pump Specification
agsssimpler11_16panel3ph	UNI-JET T2 75 120 415vac 50hz 0.4kw 1.4A
agsssimpler14_20panel3ph	3 Phase Pump With 1.4-2.0 Running Current
agsssimpler28_40panel3ph	TECNO JET T2 130 415vac 50hz 1.1kw 3A
agsssimpler22_32panel3ph	TECNO JET T2 130 415vac 50Hz 0.75kw 2.7A
agsssimpler35_50panel3ph	FLUX JET 142 415vac 50hz 1.5kw 4a Pump
agsssimpler45_63panel3ph	3 Phase Pump With 4.5-6.3 Running Current

Pump/ Overload & Motor Rated Fuse Variations

Single Phase Pump Specification	Overload Variation	Pump Mount (Foot)
UNI-JET 75 120 230vac 0.4Kw 3.1A	Overload Siemens 2.8-4.0amp SH359	A20/15 M6x15-57 SH256
TECNO JET 130 230vac 0.75Kw 6A	Overload Siemens 5.5-8.0amp SH361	A20/15 M6x15-57 SH256
FLUX JET 141 230vac 1.1Kw 7.6A	Overload Siemens 7.0-10.0amp SH523(J)	A30/15 M8x20-57 SH261
FLUX JET 141 230vac 1.5Kw 10.0A	Overload Siemens 9.0-12.0amp SH523(K)	A30/15 M8x20-57 SH261
Three Phase Pump Specification		
UNI-JET T2 75 120 415vac 50hz 0.4kw 1.4A	Overload Siemens 1.1-1.6amp SH875	A20/15 M6x15-57 SH256
TECNO JET T2 130 415vac 50hz 1.1kw 3.0A	Overload Siemens 2.8-4.0amp SH359	A20/15 M6x15-57 SH256
TECNO JET T2 130 415vac 50Hz 0.75kw 2.7A	Overload Siemens 2.2-3.2amp SH358	A20/15 M6x15-57 SH256
FLUX JET 142 415vac 50Hz 1.5kw 4.0A	Overload Siemens 3.5-5.0amp SH360	A30/15 M8x20-57 SH261
Customers Own Pump	Running Current Stated Pump Inspection Plate	Use Pump Manufacturers Recommended Mount

History

- 1.0 Issued For ISO13485
- 1.1 Updating of Parts Lists & Maintenance
- 1.2 Updated to Include information on validated information
(Environment, Symbols, Labelling, & Structural)
- 1.3 Updated to include EU MDR Label